

Würth Electronics USB 3.0 Bundle



-Advantages of new USB 3.0 standard

-WR-COM Connectors and Cable Solutions

-EMI Protection: WE-CNSW Common Mode Chokes

-ESD Protection: WE-TVS Diodes

Welcome to Würth Electronics Product Training Module for USB 3.0 applications. Würth Electronics is offering a whole bundle of products for the new USB superspeed standard, which includes a complete connector and cable assembly solution, as well as common mode line filters and TVS Diodes to protect the ports from EMI and ESD. First, Würth Electronics will show the superior characteristics of the new Universal Serial Bus standard.

Advantages of the new USB 3.0 (superspeed) standard



- Up to 10x higher data rate than USB 2.0 (4.8Gbps vs. 480Mbps)
- Separate data lanes for upload and download allow to read and store files at the same time
- Due to higher current capability, quicker charge through USB of mobile devices
- Better power efficiency due to interrupt-driven protocol
- Backwards-compatible to USB 2.0 standard

Before going into detail about Würth Electronics product offering for USB 3.0 (also known as USB Superspeed), we would like show the advantages of the new Universal Serial Bus Standard.

USB 3.0 has a data rate up to 10 times higher than USB 2.0 and allows max data speeds of 4.8Gbps. Due to the separation of data lanes for upload and download, the new standard is not only quicker, it even allows the device to read and store files at the same time. An additional advantage is the more intelligent power management, which allows a quicker charge of USB chargeable devices and is also equipped with an interrupt-driven protocol. This means non-active or idle devices (which aren't being charged by the USB port) won't have their power drained by the host controller as it looks for active data traffic. Last, but not least, the new USB 3.0 standard is fully backwards-compatible to USB 2.0.

Würth Electronics line-up for USB 3.0 applications



TM & © 2008 USB-IF All rights reserved.



Würth Electronics, due to the broad manufacturing program, is able to provide an electronic design engineer with four essential components needed for USB 3.0 designs. In addition to offering a line of fully compatible USB connectors and cable assemblies, Würth Electronics is also manufacturing high frequency, common mode line filters, and TVS diodes for highspeed applications like USB 3.0. Technical details about each individual product series will follow on the next slides.

WR-COM USB Connectors and Cable Assemblies



Connectors and Cable Assemblies compatible to new USB 3.0 standard

Characteristics:

- Full offering of connectors compatible to all requirements of USB 3.0 (superspeed) in all common configurations
- Blue color (superspeed standard)
- High temp LCP plastic used in all Connectors
- RoHS, REACH & Halogen-Free
- Selective gold plating of contacts for up to 5000 mating cycles
- Connectors: reflow and wave solderable!



Wurth Electronics' WR-COM USB3.0 connector series is distinguished by its superior quality and the full-fulfillment of all requirements needed for the Universal Serial BUS superspeed standard. The series contains a full program of connectors in all common configurations, as well as standard cable assemblies for test purposes. All connectors are equipped with blue color, high temperature, LCP plastics, and they are completely compatible to RoHS, REACH, and Halogen-Free standards. Due to the selective gold contact plating, up to 5000 mating cycles are possible. All connectors in the WR-COM series are wave and reflow solderable.

WR-COM USB Connectors and Cable Assemblies



Connectors and Cable Assemblies compatible to new USB 3.0 standards

Family Overview:

Connectors:

Part Number	Digikey Part Number	Type	Configuration	Mounting Style	Feature
692121030100	732-3146-2-ND	Receptable	1x1 A Type	THT	Standard
692121130100	732-3148-2-ND	Receptable	1x1 A Type	THT	Reverse Offset 0.14mm
692121230100	732-3147-2-ND	Receptable	1x1 A Type	THT	Reverse Offset 1.04mm
692121330100	732-3149-2-ND	Receptable	1x1 A Type	THT	Reverse Offset 1.75mm
692122030100	732-3150-2-ND	Receptable	1x1 A Type	SMD	Standard
692112030100	732-3157-ND	Plug	1x1 A Type	SMD	Standard
692141030100	732-3156-ND	Receptable	2x1 A-Type	THT	Standard
692221030100	732-3158-ND	Receptable	1x1 B Type	THT	Standard
692622030100	732-3151-2-ND	Receptable	1x1 microB Type	SMD	Standard



Cable Assemblies:

Part Number	Digikey Part Number	Connection 1	Connection 2	Length
692901100000	732-3177-ND	A Plug	A Plug	1m
692902100000	732-3178-ND	A Plug	A Socket	1m
692903100000	732-3179-ND	A Plug	B Plug	1m
692904100000	732-3180-ND	A Plug	Micro B Plug	1m



Würth Electronics is offering the USB 3.0 connectors in the most common connection configurations: The offer includes A, B and micro types, as well as a dual row A and plug type. Additionally, the standard A Type is available in THT and SMD mounting styles. In the cable assemblies, Würth Electronics is offering the matching plug configurations. The cables are available in a standard length of 1 meter and are also equipped with the blue color to signify the USB 3.0 speed. All connectors and cable assemblies are in stock available under the displayed part numbers at Digikey.com.

WE-CNSW HF Series



Common Mode Noise Filter for High Speed Data Lines

Characteristics:

- Current compensated data line filter
- High common mode noise suppression at high frequencies
- Small influence on high speed signals through winding symmetry
- Operating temperature: $-40\text{ }^{\circ}\text{C}$ to $+125\text{ }^{\circ}\text{C}$
- Small 0805 package size

Applications:

- USB 3.0
- LVDS
- HDMI
- Other high speed data lines



Aside from the interconnect products for USB superspeed, Würth Electronics is also offering the best EMI filtering components for the new standard. Like with USB 2.0, it will be also a necessity to have an EMI filter which suppresses common mode noise in the high MHz area. Würth Electronics' WE-CNSW series is tuned to give an optimum EMI suppression with a little-to-no influence to the data signal. The CNSW HF series in its small 0805 package size is designed to meet industrial temperature requirement up to $125\text{ }^{\circ}\text{C}$ operating temperature. Besides USB 3.0, the WE-CNSW HF finds its usage in other high speed bus systems like LVDS or HDMI.

WE-CNSW HF Series



Family Overview:

Part Number	Digikey Part Number	Impedence @ 100MHz	Rated Current	Typical Application
744231091	tbd	90Ohm	370mA	USB 2.0
744233670	732-2577-2-ND	67Ohm	320mA	USB 3.0
744233900	732-2578-2-ND	90Ohm	280mA	HDMI
744233121	732-2579-2-ND	120Ohm	280mA	LVDS / USB 2.0



Robust USB Port EMI Protection:

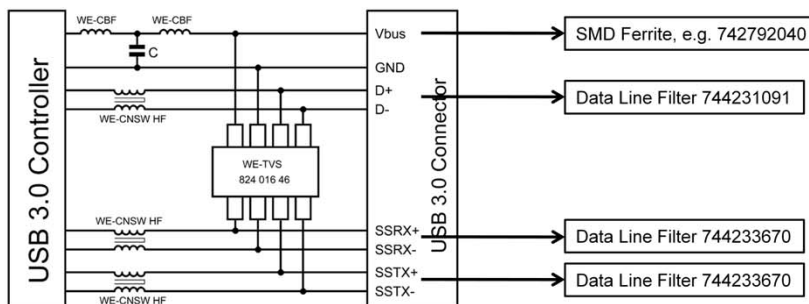

Wurth Electronics WE-CNSW series is available in three different impedance values, which makes the small family flexible to use in all sorts of high speed data lines. The 744233670 is designed to fit best in most USB 3.0 applications. To prevent fighting EMI after the final EMC test, a smart design engineer protects the high speed bus systems with basic protection. This contains first the protection of all data lines with an LC Filter built out of Wurth Electronics' common mode line filter, the WE-CNSW HF series, and a capacitor. For the data pair (D+/D-) Wurth Electronics recommends the use of 744231091 designed for USB 2.0 and for SSRX as well as SSTX the use of 744233670 tuned to the suppression of noise in higher frequencies. For Secondly the prevention of EMI on the voltage supply (VCC, Vbus) is supported through the placement of two Chip Bead Ferrites out of Wurth Electronics WE-CBF wide band series. An excellent chip bead ferrite for this application is for example Wurth Electronics 742792040 with 600Ohm and 2.0A for wide band filtering.

WE-TVS Super Speed Series



TVS Diode Array for High Speed Data Lines

Characteristics:

- Industry's lowest clamping voltage and ultra low capacitance
- Rail-to-Rail protection
- Standard SOT and MSOP package sizes
- Epoxy UL94 V-0 listed
- RoHS, REACH and halogen free
- Operating temperature: -40C° to +85C°



Applications:

- USB 3.0
- Display Port
- HDMI 1.3/1.4
- SATA
- Gbit LAN
- DVI



Würth Electronics' WE-TVS SuperSpeed series delivers an optimum ESD protection to your highspeed bus design. The TVS diodes from Würth Electronics are distinguished with the industry's lowest clamping voltages and low capacitance,s which leads to the best possible protection of the circuit. The Diode Arrays are available in the most common SOT and MSOP package sizes and have UL94 V-0 listed Epoxy. All diodes from Würth Electronics are fully RoHS, REACH and Halogen-Free and are rated for industrial operating temperatures up to +85°C. Würth Electronics' WE-TVS diodes are suitable for other high speed bus systems like HDMI, Gigabit LAN, SATA, DVI and Display Ports.

WE-TVS Super Speed Series



Family Overview:

Part Number	Digikey Part Number	Size	Rev Stand-off Voltage	Rev Breakdown Voltage	I/O	Channel Input Capacitance	Channel to Channel Input Capacitance	Typical Application
82401646	732-2505-2-ND	MSOP-8L	5V	6V	6+1	0.2pF	0.05pF	USB 3.0 HDMI 1.4
82401444	732-2504-2-ND	MSOP-10L	5V	6V	4+1	0.6pF	0.10pF	HDMI 1.3 DVI Display Port
824014	732-2503-2-ND	SOT23-6L	5V	6V	4+1	0.6pF	0.10pF	



Schematic of a typical USB 3.0 application:

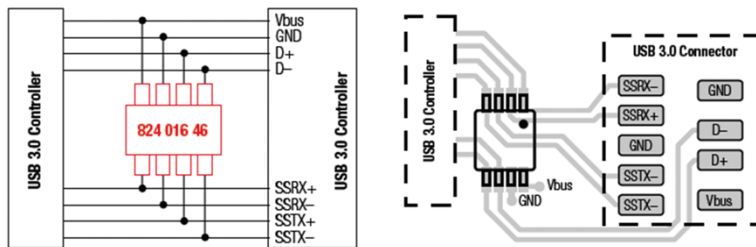

Würth Electronics WE-TVS Superspeed series contains three different package sizes: MSOP-8L, MSOP-10L and SOT23-6L. The TVS Diodes are designed to fit into several high speed interfaces like HDMI and DVI. For USB 3.0, with its number of data lines and Vbus plus ground, the TVS diode, 82401646, is designed to protect all lines from ESD. Below the table, you can find a typical schematic for a USB 3.0 port with a full ESD protection of all circuits.

In Summary



TM & © 2008 USB-IF. All rights reserved.

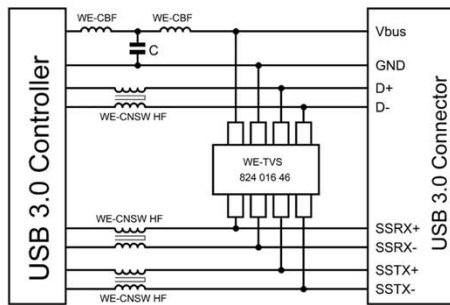

In summary, Wurth Electronics offers to the industry a complete Interconnect, ESD and EMC solution for the new USB 3.0 (also known as superspeed) standard. All products shown are in stock at digikey.com.